



FEATURES

- Suitable for chlorinated environments
- Public, Private & Remote Allocation System (RAS) mode
- Key override
- Up to 80,000 cycles per pair of AA batteries
- Batteries included
- Battery condition indicator
- Audible keypad (can be turned on/off)
- 8 digit master code
- 6 digit sub-master code
- 4 digit user codes
- 6 digit technician code
- Auto unlock mode (can be turned on/off)
- Technician mode

OPTIONS

- Finishes:** Black (B), Silver (S), White (W), Custom*
- Keypad Direction:** Vertical (V), Right (R), Left (L)
- ADA Wet Area Kit (A)
- Remote Allocation System (RAS)

DIMENSIONS & SPECIFICATIONS

External Dimensions:

- Length: 140mm (5 1/2")
- Width: 41mm (1.61")
- Depth: 32.5mm (1.28")

Mounting Hole Shape: 2 or 3 point mounting (see technical drawing)

Spindle Length: 16mm standard, 20mm by special order*

Power: 2 x AA Battery (Alkaline)

Operations: Up to 80,000 cycles per pair of AA batteries

Low Battery: LED lights with battery condition indicator

Material: Zinc diecast

Finish: Powder coated

Standard Cam Capability: 1/4" to 1 1/2"

Keys Included: 2

IP65 Rated

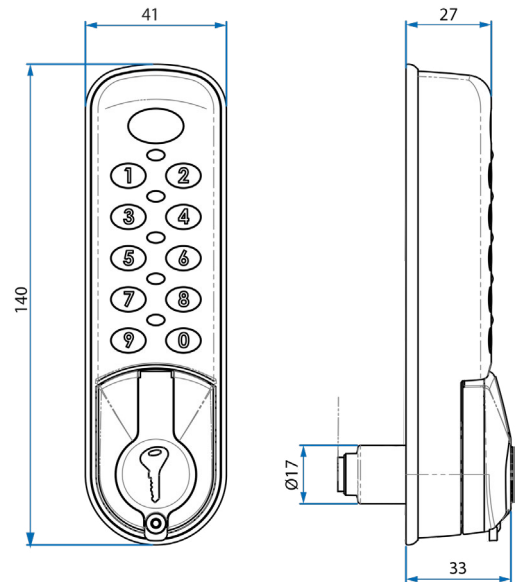

ORDERING INFORMATION

Order # for EC781 shown above is EC781BV

| Order # | Finish | Keypad Direction | ADA Kit | RAS |
|---------|-------------------------------------------------|---------------------------------------|---------|-----|
| EC781 | (B) Black (S) Silver (W) White Custom* | (V) Vertical (R) Right (L) Left | A | RAS |

*Contact LockeyUSA for minimum order quantities and lead times for custom orders.